

CellLog 8M

Cell Voltage Monitor



USER'S MANUAL

SHENZHEN JUNSI ELECTRONIC CO.,LTD



Thank you for purchasing the **CellLog 8M**. Please read the entire User's Manual completely and attentively as it contains a wide variety of specific programming and safety information.

Specifications

Lithium (LiPo/LiIo/LiFe) battery cell count:	2 – 8 series
Pack voltage range:	4.0 – 43.0VDC (USB can provide lower voltage 1.0V)
Alarm pack voltage range:	0.1 – 43.0VDC
Cell voltage range:	1.3 – 4.9VDC
Alarm cell voltage range:	1.3 – 4.9VDC
Voltage display resolution:	1mV
Current loading of test:	8mA
Maximum voltage for alarm port:	50VDC
Current drain for alarm port:	<500mA
Weight:	17g
Dimensions (L X W X D):	62X39X12mm 2.44”X1.53”X0.47”

Special features



- Small size with multiple functions, backlight 128*64 lattices LCD and Buzzer Tone Reminder; the interface can be operated smoothly.
- **CellLog 8M** can not only measure 2-8S Li battery individual voltage, but also measure NiMH, NiCd, Pb battery pack voltage.
- It can be set Individual Voltage Alarm and Pack Voltage Alarm, Overvoltage Alarm, Low Voltage Alarm, Differential Voltage Alarm and Time Over Alarm. What's more, the extra alarm output can be linkage controlled by the users.
- It has 8 sets default monitor alarm settings, which can be selected for different battery packs.
- **CellLog 8M** has been 100% calibrated before it enters to the market, at the same time, it supports the calibration by users themselves.



Unpack inspection

The following items are included in the package. Contact your supplier if any items are missing.

Standard items:

CDROM	
85 X 85mm	
One copy of the User's manual on CDROM	
CW-P220	CW-C220
	
20mm	20mm
One Alarm output line	One pack voltage measurements line with clips

Optional items:

See details in "Optional parts" (P14)



External controls and connections



1. Input plug 2. LCD screen 3. Function button 4. Beep 5. Alarm port

CellLog 8M Connection Diagram

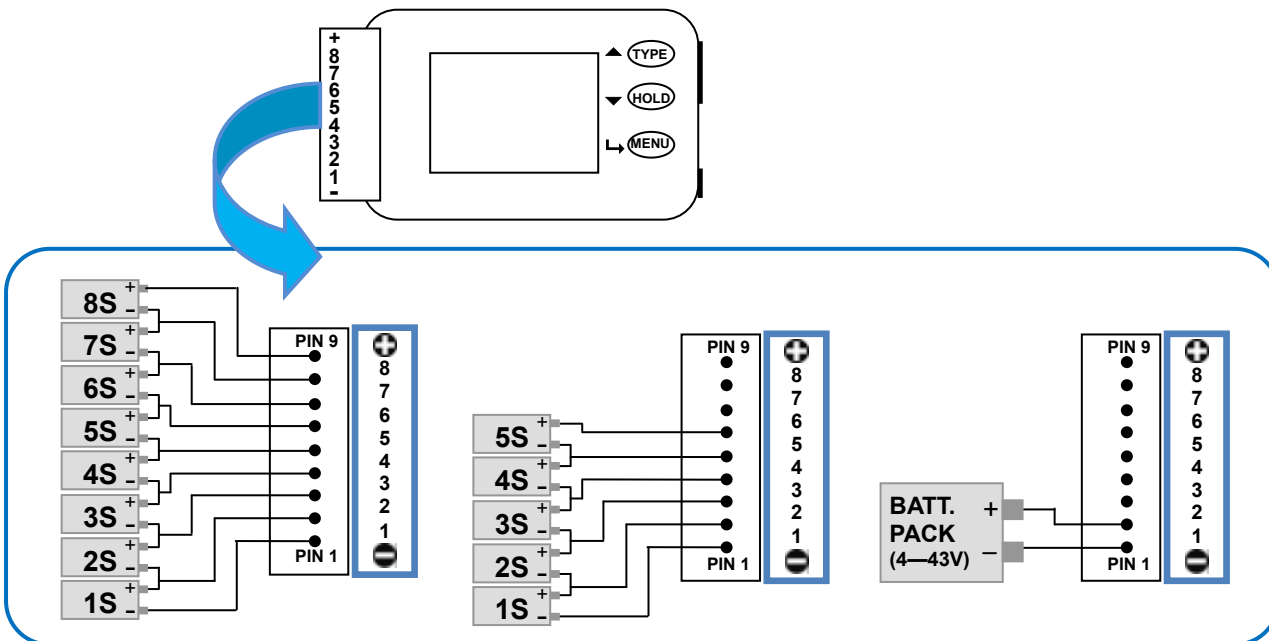



Program flow chart

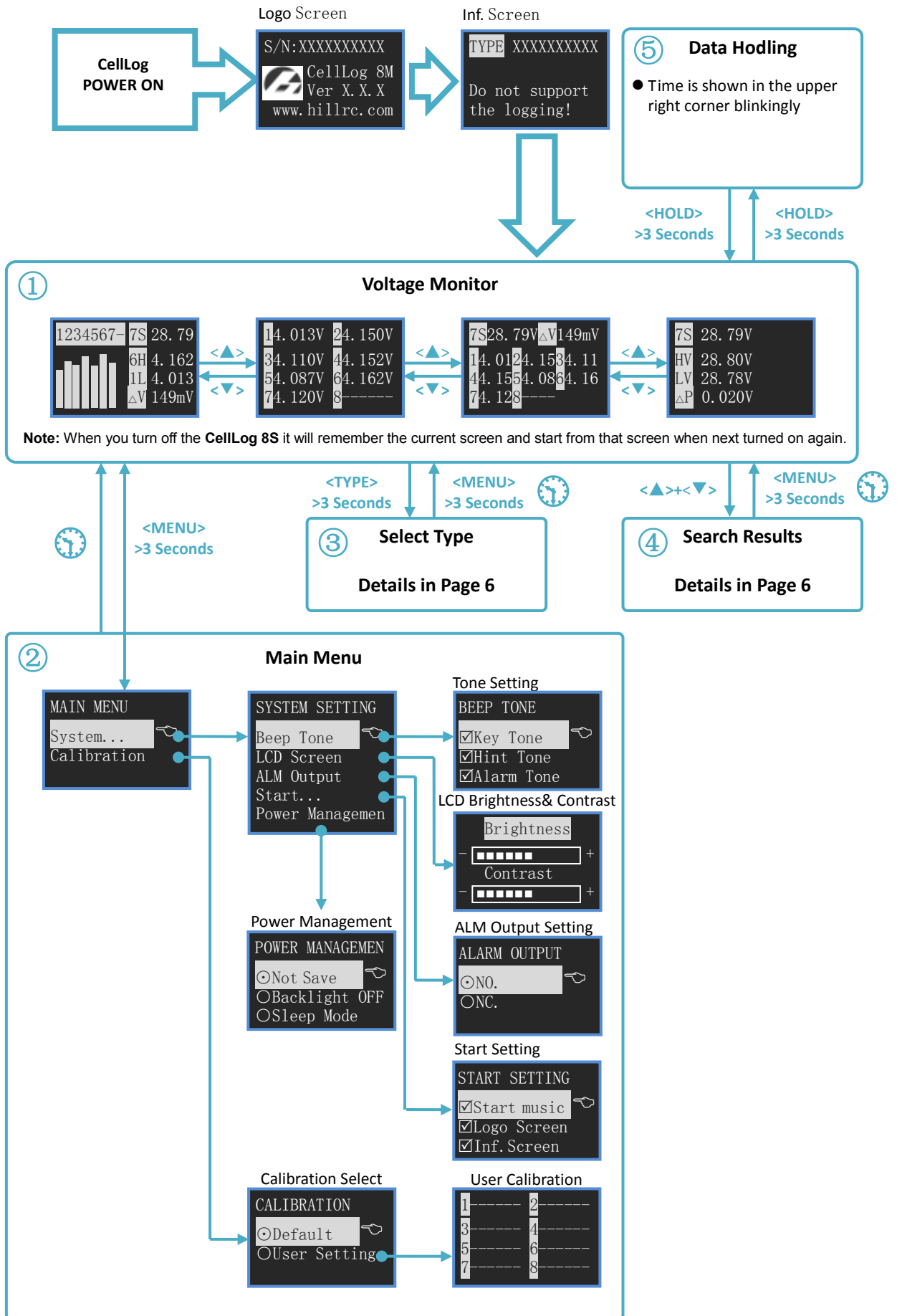

Note: means if no operation on the button for 1 minutes, the system will return to monitor screen automatically.

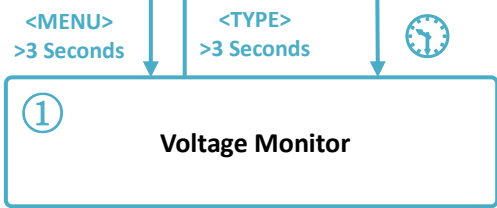
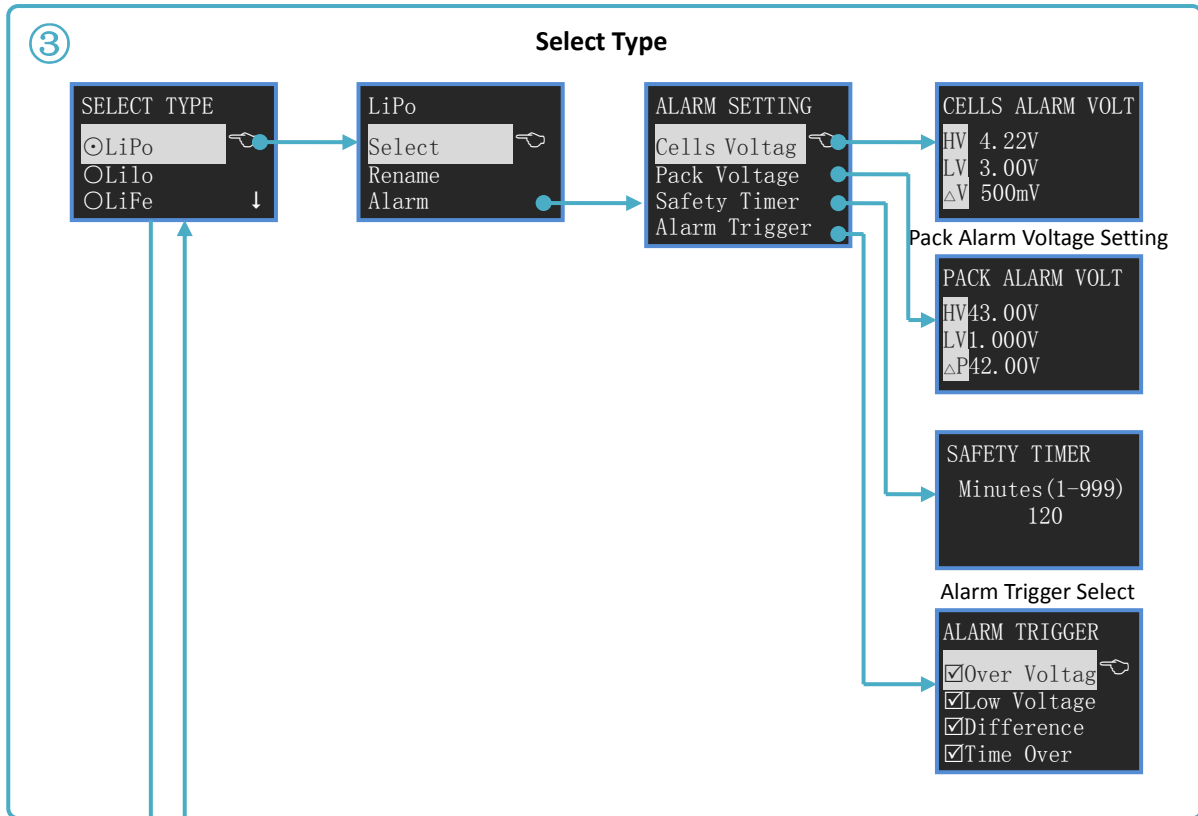

Note: means if no operation on the button for 1 minutes, the system will return to monitor screen automatically.

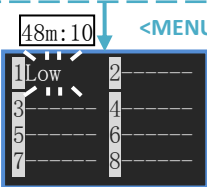
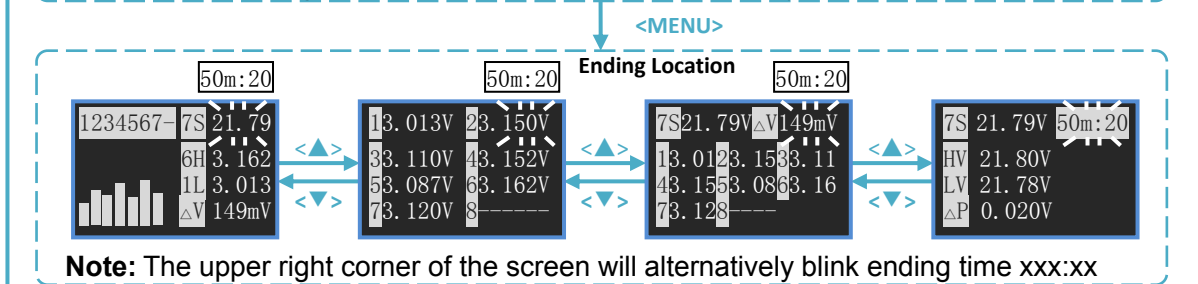
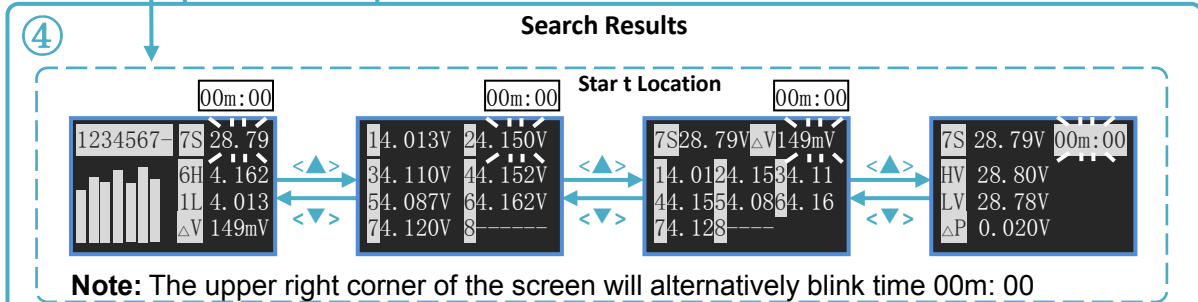

Alarm time points
If there is alarm, the alarm events/alarm time will be shown alternatively at the corresponding battery number place.



Menu Operation:

1. Select the menu items by <▲> /<▼> buttons, the selected item will be shown in white.
2. Press <↔> to the following menu, and hold <↔> for more than 3 seconds, it will return to the upper menu.

Symbol Meanings:

Display Symbols	The meaning of the Symbols	Note
nS	total voltage of the pack	n:0-8, the cell count
nH	the highest individual cell voltage	n:0-8, the highest cell number
nL	the lowest individual cell voltage	n:0-8, the lowest cell number
ΔV	the maximum voltage difference between the cells	$\Delta V = nH - nL$
HV	The voltage maximum value	
LV	the voltage minimum value	
ΔP	the pack maximum voltage difference	$\Delta P = HV - LV$
$mmM:ss$ or $hhH:mm$	the time entering to logging	ss:second ,mm:minute , hh: hour
\odot/\circ	Single choice Do/Do not	
\checkmark/\square	Multiple choice Do/Do not	
T_OVER	Safety time alarm	
LOW	Low voltage alarm	
OVER	Over voltage alarm	
DIFF	Voltage difference alarm	

Button Function

CellLog has 3 buttons, which everyone owns the first and second functions. The first function is trigger after only one click; the second function is trigger after 3 seconds holding of the button.

Press button	Condition	Button Function Description
<▲>	Click	1. Turns up the menu 2. Increase the value 3. Select the character input
	Hold for 3 seconds	Enter to Alarm type select menu
<▼>	Click	1. Turns down the menu 2. Decrease the value 3. Delete the character
	Hold for 3 seconds	Trigger Open/Close Logging Function
<↔>	Click	Confirmation
	Hold for 3 seconds	Enter to System Setting Menu
<▲>+<▼>	Click	Check holding information
	Hold for 3 seconds	Save users voltage calibrated value

Note: <▲>+<▼> means pressing <▲> and <▼> at the same time.



QUICK START

● CellLog Power On

(2 ways: one is connecting the battery through the left 9 Pin socket, the other one is through the USB port), System self-check, and then shows the SN and version number, the display information are as below:

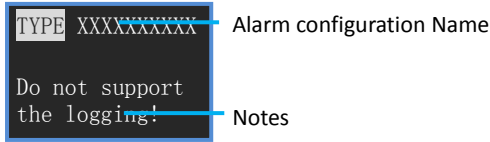

The first line is the current selected **Setting Type** (See detail in P10).

Note: CellLog 8M has no Logging function, if it is necessary, please choose CellLog 8S.

● Voltage Monitor

There are 4 interface choices, which can be shifted by <▲> or <▼> buttons.

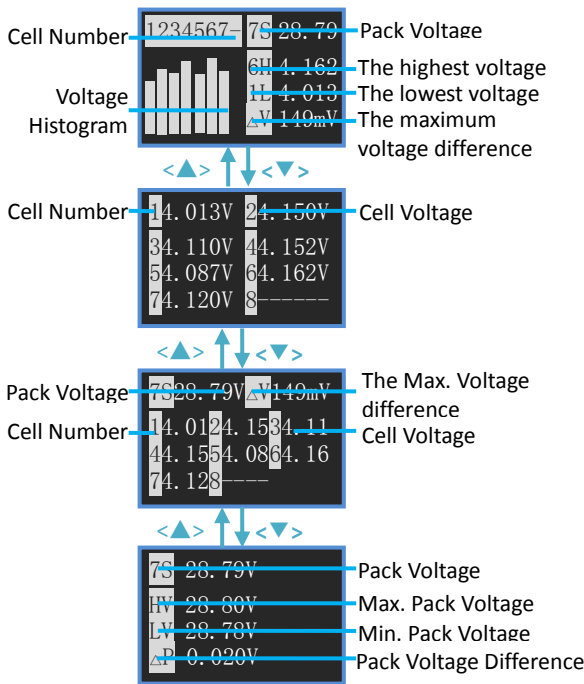

As the left pictures: the '7' in "7S" means cell counts; '6H' means the 6th cell voltage is the highest; '1L' means the 1st cell voltage is the lowest.

If the monitor voltage trigger alarm, the corresponding voltage and alarm display (LOW, OVER or DIFF) shows alternatively.

The cell number and (L, O, D) shows alternatively.

'LOW' or 'L' means: Low voltage alarm

'OVER' or 'O' means: Over voltage alarm

'DIFF' or 'D' means: Voltage difference alarm. They will be displayed at the same time at the highest and the lowest cell voltage interface.

Monitor the pack voltage

Display respectively: Current pack voltage, Max. Pack voltage, Min. Pack voltage, Pack voltage difference. (△P = HV-LV)

● Data Holding

When in **Voltage Monitor** status, press <▼> button for 3 seconds, after it shows "Start holding...", the calculagraph will be shown alternatively at the upper right corner of the LCD screen. Press <▼> for 3 seconds again, the screen will show "Stop holding!" and then exit.

● View holding Point

In the monitor status, press <▲> and <▼> at the same time to enter the view logging point status. Three points voltage data can be searched: "Starting holding..." data, "Stop holding!" data, and the data of voltage alarm during this period, which can be shifted by <←> buttons. Press <←> for 3 seconds, it will return to the monitor status.

The saved data can be covered till next logging.

If the logging time is over the users setting safety time, (See **Monitor Safety Time Setting** in P11), it will trigger Safety Time Alarm, and the screen shows "T_OVER" alternatively in the upper right corner.



● Alarm Remind

If CellLog detect the alarm events (See **Alarm Trigger Settings** in P11), it will remind as below:

1. The buzzer beeps every 4 seconds (【Alarm Tone】 is selected , See P12) .
2. The corresponding individual voltage and alarm remind show alternatively.
Alarm Remind Information: “LOW”, “OVER”, “DIFF”, “T_OVER”
3. ALM port will output the presetting signal.

ALM port signal information:

ALM output port signal is open collector signal, as showed below.

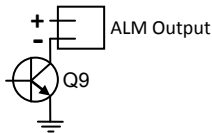

Please pay attention to the port voltage and current limit when you use (<50V,<500mA)

The following are ALM Output typical application.

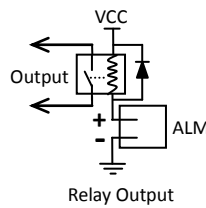
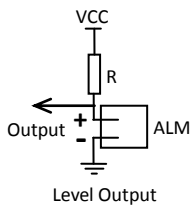



Monitor Alarm Settings

The system can have 8 sets alarm settings, press <▲> for 3 seconds to enter **SELECT TYPE** menu.

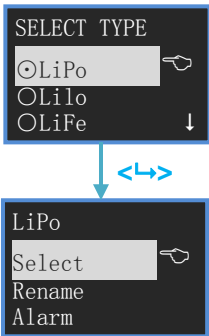

The item with ⊙ is the current setting.
<▲> or <▼> to select items and press <↔> button.
Defaulted TYPEs are: LiPo, Lilo, LiFe, User1--5

Operate the selected type settings
<▲> or <▼> to select the items, press <↔> to enter to the next step.
See details below.

- Note:** Press<▲> button to power on, it will shift to LiPo Type automatically.
- Press <▼> button to power on, it will shift to Lilo Type automatically.
- Press <↔> button to power on, it will shift to LiFe Type automatically.

- **Change Current Alarm Type:** Select **【Select】** , Press <↔> then the item will be with ⊙, and the settings come into effect.

- **Rename Alarm Type:** Select **【Rename】** , press <↔> and the screen shows:

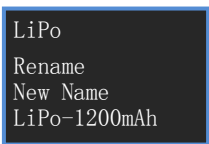

New Name Input Method: <▲> to select characters, hold it to trigger continuously; <▼> to delete the current character; <↔> to confirm the selected character; press <↔> for 2 times to confirm the amendment and return; press <↔> for 3 seconds to cancel and return.

- **Alarm Parameters Setting:** Select **【Alarm】** , press <↔> and the screen shows:

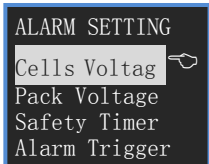

<▲> or <▼> to select items, press <↔> enter to the next step
See details below.

- 1) **Individual Cell Voltage Alarm Settings:** Select **【Cells Voltage】** , press <↔> and the screen shows:

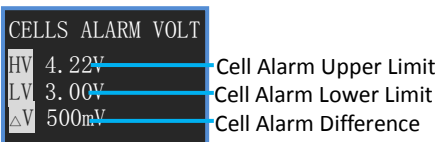

<▲> or <▼> to increase/decrease voltage value, press <↔> to shift setting items. Press <↔> for 3 seconds to confirm amendment and return.
[HV]: 1.31V—4.90V [LV]: 1.30V—4.89V [ΔV]: 0.01—3.60V

- 2) **Pack Alarm Voltage Setting:** Select **【Pack Voltage】** , press <↔> and the screen shows:

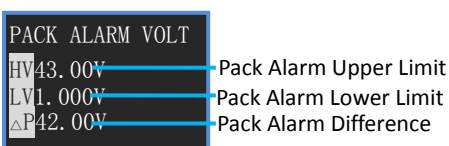

<▲> or <▼> to increase/decrease voltage value, press <↔> to shift setting items. Press <↔> for 3 seconds to confirm amendment and return.
[HV]: 1.05V—43.00V [LV]: 1.00V—42.95V [ΔP]: 0.05—42.00V



3) **Monitor Safety Time Setting:** Select **【Safety Timer】** , press **<↔>** and the screen shows:

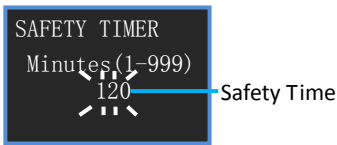

<▲> or <▼> to increase/decrease, press **<↔>** to confirm amendment and return. Press **<↔>** for 3 seconds to cancel amendment and return. Setting range: 1—999 minutes

4) **Alarm Trigger Settings:** Select **【Alarm Trigger】** , press **<↔>** and the screen shows:

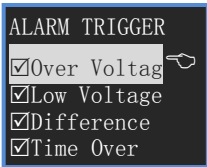

<▲> or <▼> to select items, press **<↔>** to shift select /, press **<↔>** for 3 seconds to confirm amendment and return.

Select **【Over Voltage】** Cell or pack voltage are over setting value, then it alarms.

Select **【Low Voltage】** Cell or pack voltage are lower setting value, then it alarms.

Select **【Difference】** Cell voltage is over or the pack voltage difference is over setting value, then it alarms.

Select **【Time Over】** entering HOLD status time is over setting safety time ,then it alarms.



Parameter Setup

Press <L> for 3 seconds, and enter to the **MAIN MENU**, Monitor status.

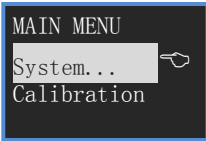

System Settings: Select **System...** , press <L>, the screen shows:

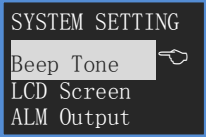

<▲> or <▼> to select items, press <L> to have a select item, press <L> for more than 3 seconds to return.
See details below.

1) **Beep Tone Settings:** Select **Beep Tone** , press <L>, the screen shows:

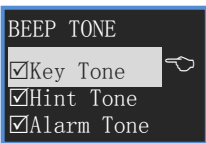

<▲> or <▼> to select the items, and press <L> to shift select /, press <L> for 3 seconds to confirm the amendment and then return.
Select **Key Tone** ,the buttons tone open.
Select **Hint Tone** ,the status tone open.
Select **Alarm Tone** ,the alarm tone open. (“Do” every 4 seconds)

2) **LCD Brightness & Contrast Setting :** Select **LCD Screen** , press <L>, the screen shows:

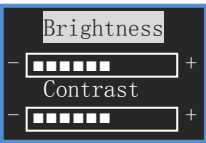

<▲> increase, <▼> decrease, and press <L> to shift Brightness/Contrast, press <L> for 3 seconds to confirm the amendment and then return.

3) **Alarm Output Signal Type Setting: ALARM Output**

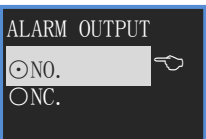

NO. : Always On. Two output of ALM, it’s open when there is no alarm; It’s short circuit with alarm.
NC. : Always Close. Two output of ALM, it’s short circuit when there is no alarm; It’s open with alarm.

4) **Start-up Setting: Start...**

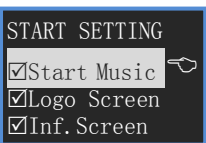

<▲> or <▼> to select the items, and press <L> to shift select /, press <L> for 3 seconds to confirm the amendment and then return.
Select **Start Music** , there will be a start music if you turn on
Select **Logo Screen** , it will display Logo Screen if you turn on
Select **Inf. Screen** , it will display Information Screen if you turn on

5) **Power management Setting: Power management**

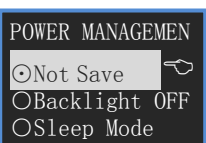

The item with ⊙ is the current setting.
Not Save , power save function turns off
Backlight OFF , turns off LCD backlight
Sleep Mode , turns off LCD backlight & MCU enters to Sleep Mode

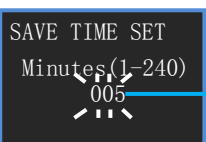

Press <L> to **Save Time Set**
No operation in setting time, the system will enter to the selected Power Save Mode automatically. Press any key to normal Mode.



Calibration Settings: Select **【Calibration】** , and press **<↔>**, the screen shows:

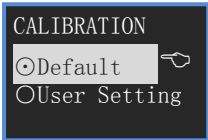

【Default】 : Calibration Default.
【User Setting】 : See details in P13

User Calibration

The **CellLog 8M** has been calibrated before entering to the markets, but if the users find that there is too much deviation, and then they can calibrate it as the following items:

Before calibration, you need prepare:

- 8s battery pack (the individual voltage ranges from 3.8-4.2V)
- 4½ Digital Multimeter

Calibrating steps:

1. Connect pack balance port to **CellLog 8M** to confirm there are 8 cell voltage display.
2. Press **<MENU>** for 3 seconds to enter *Main Menu*-- **【Calibration】**-> **CALIBRATION**-- **【User Setting】** ,then it shows:

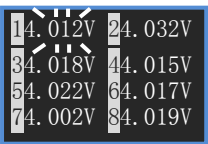

3. The current need-to-be calibrated voltage begins to blink (shows the voltage and calibrated value alternatively) , and use multimeter to measure the individual voltage corresponding to the blinking voltage. If the displayed value is more than the measured value, please press **<▼>** to decrease the displayed value to the measured value; vice versa, please press **<▲>** to increase the displayed value to the measured value. Press **<↔>** and shift to the next voltage calibration. In this way to get 8 sets voltage calibration.

4. Press **<▲>** and **<▼>** for 3 seconds to save the amendment and exit; Press **<↔>** for 3 seconds, it will cancel the amendment and exit.

5. The above is only for 8S individual cell measurement calibration, the methods are same for CellLog 8M measure port 1, 2 to measure pack voltage calibration.

Connect 1, 2 to the battery pack's negative and positive pole respectively, then follow the **Step 2, 3, 4.**

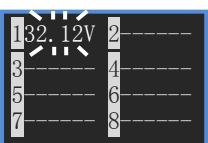

Note:

- **If the user calibrates it in a wrong way, which damage the battery or cause other serious danger, our company will be of no responsibility.**
- **The users' calibrated value will not affect the calibrated before entering to the market. It can be selected by CALIBRATION-- **【User Setting】** or **【Default】** .**